

Fassmer Rescueboats

Fast Rigid Rescueboat (FRR)



FR(I)R Fast Rescue Boat

This relatively large boat is intended as a rescue boat for Ro-Ro passenger ferries, cruise ships, work vessels (supply ships, buoy layers, cable layers, pipe layers) and offshore oil platforms. It features compact, lightweight variable modular construction. It is optionally available in a semi-rigid version of fiberglass-reinforced polyester resin (FRP) and an inflatable collar or in a rigid all-FRP version. The boat is driven a powerful outboard motor with a rating of up to 103 kW (140 h.p.). Foam sandwich construction makes this boat absolutely un-sinkable, and internal foam flotation rights the boat in the event the boat capsizes. The boat is moved on a permanently installed hoisting hook with water pressure protection. The boat is approved in compliance with IMO MSC / Circ. 809.

Fr. Fassmer GmbH & Co. KG

Industriestraße 2
D-27 804 Berne/Motzen
Phone +49 44 06 942-0
Fax +49 44 06 942-100
www.fassmer.de

Fassmer Rescueboats

Fast Rigid Rescueboat (FRR)

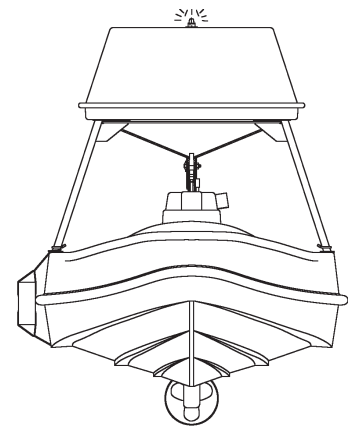
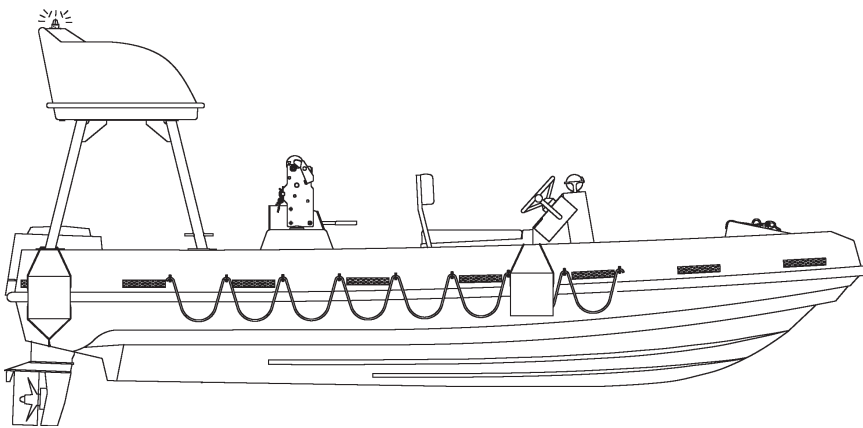

Type	Length (L) (m)	Breadth (B) (m)	Height over all (m)	Weight w/o persons (kg)	Persons max.	Speed c/w 3 persons
FRR 6.1	6.10	2.23	2.60	1110-1220	10	20-34

Engine: 44-103/2 x 29 – 2 x 51 kW (60 - 140 / 2 x 40 - 2 x 70 hp) petrol outboard engine