



**FASSMER**

## **Fassmer Lifeboats according to SOLAS-LSA-Code 4.6, 4.7, 4.8**

For Cargo Ships and Tankers



### **Totally Enclosed Lifeboat GMR/TGMR**

This unsinkable lifeboat for cargo vessels, tankers and work vessels is also used as a combination lifeboat-rescue boat. Fiberglass-reinforced polyester resin (FRP) permits exceptional stability and a long service life. The boat features compact, lightweight design and is powered by a diesel engine with a sealed cooling system. It is approved in compliance with LSA Code 4.6 (4.8, 4.9 for tankers).



### **Fr. Fassmer GmbH & Co. KG**

Industriestraße 2  
D-27 804 Berne/Motzen  
Phone +49 44 06 942-0  
Fax +49 44 06 942-100  
[www.fassmer.de](http://www.fassmer.de)

## Fassmer Lifeboats according to SOLAS-LSA-Code 4.6, 4.7, 4.8

For Cargo Ships and Tankers

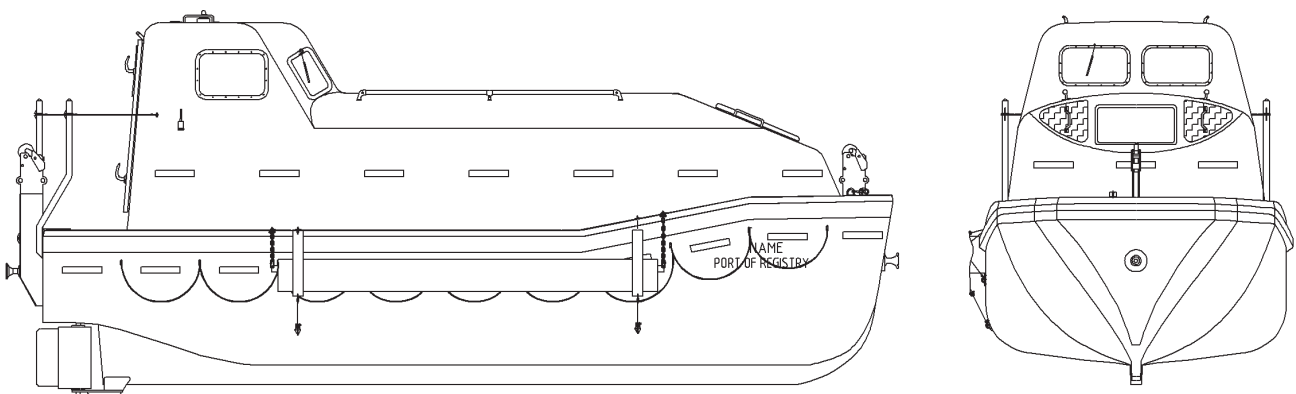

### Davit launched totally enclosed lifeboats

Type	Length (L) (m)	Breadth (B) (m)	Registered height (mm)	Weight w/o persons (kg)	Persons max.
<b>Cargo Ships</b>					
GMR 5.9*	5.90	2.30	1.03	2250	27
GMR 6.5*	6.50	2.30	1.03	2350	32
<b>Tankers</b>					
TGMR 5.9*	5.90	2.30	1.03	2550	27
TGMR 6.5*	6.50	2.30	1.03	2550	32

(\* approval as rescueboat according to LSA Code 5.1 also possible)